



Paranchi manuali a catena serie FH

FH series manual chain hoists

SERIE FH
 Portate fino a 5 t

FH SERIES
 WLL up to 5 t

CARATTERISTICHE SPECIFICATION

- Compact and robust steel body
 - Sure and reliable mechanical brake with safety pawl
 - Zinc plated load chain according to EN 818-7
 - Trolley wheels with ball bearings
 - Safety lugs
 - Rubber bumpers
- Corpo di acciaio robusto e compatto
 - Freno sicuro e affidabile con saltarello di sicurezza
 - Catena di carico elettrozincata a norme EN 818-7
 - Ruote carrello su cuscinetti
 - Staffe anticarrucolamento
 - Respingenti in gomma

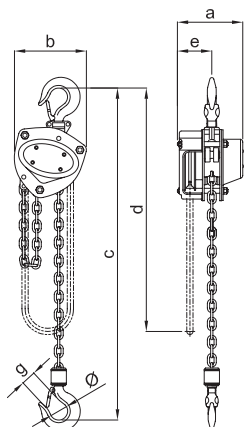
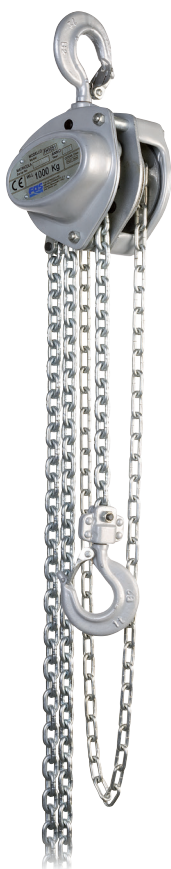

FH/1G

Con gancio di sospensione
 With hook suspension

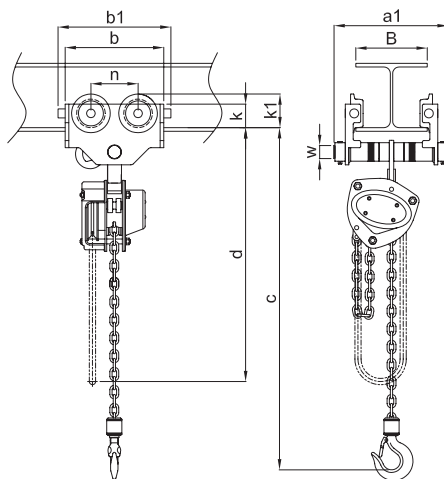

FH/2S

Con carrello a spinta
 With plain trolley

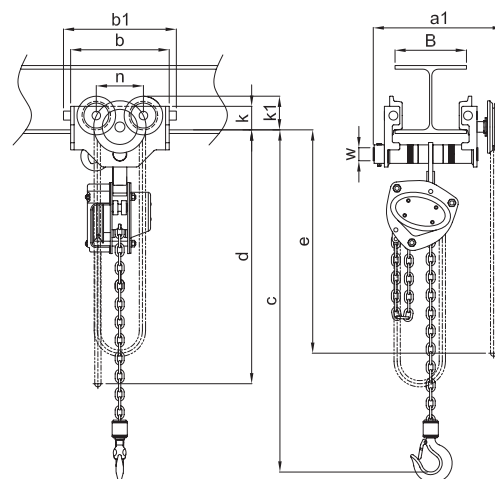

FH/2

Con carrello meccanico
 With geared trolley



Paranchi manuali a catena serie FH

FH series manual chain hoists

SERIE FH
Portate fino a 5 t

FH SERIES
WLL up to 5 t

TIPO FH/1G CON GANCIO DI SOSPENSIONE FH/1G TYPE WITH HOOK SUSPENSION

Portata WLL	Tipo Type	Corsa gancio STD Std Lift	Catena di manovra STD Std hand chain	Trazione alla catena di manovra Chain pull to lift full load	Catena svolta per sollevare un metro Chain pulled to lift load 1 m	Carico di prova Test load	Minima quota Min. headroom	Dimensioni Dimensions							Catena di carico Load chain		Peso netto Net weight	Peso per m addizionale di corsa gancio Weight for additional one meter lift
								a	b	d	e	g	ø	Diametro x tiri Diameter x falls	n°	Kg		
t		m	m	Kgf	m	t	C mm	a mm	b mm	d mm	e mm	g mm	ø mm	mm	n°	Kg	Kg	
0,5	FH5S1/1G	3	2,5	25	25	0,75	280	128	130	3000	75	22	20	5	1	9	1,5	
1	FH10S1/1G	3	2,5	29	43	1,5	330	142	150	3000	76	26	25	6,3	1	12	1,8	
1,5	FH15S1/1G	3	2,5	34	57	2,25	360	158	170	3000	80	29	30	7,1	1	15	2,1	
2	FH20S1/1G	3	2,5	35	70	3	385	175	185	3000	88	35	33	8	1	20	2,3	
3	FH30S2/1G	3	2,5	36	115	4,5	510	158	220	3100	80	37	36	7,1	2	23	3,2	
5	FH50S2/1G	3	2,5	40	199	7,5	615	183	255	3100	90	43	43	9	2	37	4,4	

TIPO FH/2S CON CARRELLO A SPINTA FH/2S TYPE WITH PLAIN TROLLEY

Portata WLL	Tipo Type	Corsa gancio STD Std Lift	Catena di manovra STD Std hand chain	Larghezza trave B Flange width B		Raggio minimo curvatura Min. radius curve	Minima quota Min. headroom	Dimensioni Dimensions								Peso netto Net weight	Peso per m addizionale di corsa gancio Weight for additional 1m of lift
				Standard	Option			a1	b	b1	d	k	k1	n	w		
t		m	m	mm	mm	mm	C mm	a1 mm	b mm	b1 mm	d mm	k mm	k1 mm	n mm	w mm	Kg	Kg
0,5	FH5S1/2S	3	2,5	52 - 152	153 - 204	800	320 (395)	240	200	240	3000	45	70	100	24	15	1,5
1	FH10S1/2S	3	2,5	66 - 203	204 - 305	1000	370 (460)	286	246	286	3000	55	80	120	30	25	1,8
1,5	FH15S1/2S	3	2,5	88 - 203	204 - 305	1100	400 (515)	317	276	316	3000	65	90	132	36	35	2,1
2	FH20S1/2S	3	2,5	88 - 203	204 - 305	1100	415 (540)	317	276	316	3000	65	90	132	36	40	2,3

- Le misure della quota a1 sono riferite a carrelli con perno standard.
- Tra parentesi quote con gancio e sospensione.
- Dimensions a1 are referred to trolleys with standard shaft.
- Between bracket dimensions with hook and suspension.

TIPO FH/2 CON CARRELLO MECCANICO FH/2 TYPE WITH GEARED TROLLEY

Portata WLL	Tipo Type	Corsa gancio STD Std Lift	Catena di manovra STD Std hand chain	Larghezza trave B Flange width B		Raggio minimo curvatura Min. radius curve	Minima quota Min. headroom	Dimensioni Dimensions								Peso netto Net weight	Peso per m addizionale di corsa gancio Weight for additional 1m of lift	
				Standard	Option			a1	b	b1	d	e	k	k1	n			w
t		m	m	mm	mm	mm	C mm	a1 mm	b mm	b1 mm	d mm	e mm	k mm	k1 mm	n mm	w mm	Kg	Kg
0,5	FH5S1/2	3	2,5	52 - 152	153 - 204	800	320 (395)	271	200	240	3000	2700	45	70	100	24	19	1,5
1	FH10S1/2	3	2,5	66 - 203	204 - 305	1000	370 (460)	329	246	286	3000	2700	55	80	120	30	27	1,8
1,5	FH15S1/2	3	2,5	88 - 203	204 - 305	1100	400 (515)	344	276	316	3000	2700	65	90	132	36	37	2,1
2	FH20S1/2	3	2,5	88 - 203	204 - 305	1100	415 (540)	344	276	316	3000	2700	65	90	132	36	42	2,3
3	FH30S2/2	3	2,5	100 - 203	204 - 305	1200	(750)	346	332	372	3100	2700	85	118	154	42	61	3,2
5	FH50S2/2	3	2,5	114 - 203	204 - 305	1300	(812)	418	380	405	3100	2700	110	130	170	48	90	4,4

- Le misure della quota a1 sono riferite a carrelli con perno standard.
- Tra parentesi quote con gancio e sospensione.
- Dimensions a1 are referred to trolleys with standard shaft.
- Between bracket dimensions with hook and suspension.